

# VIBRATION ELIMINATORS



## V SERIES

The function of a Vibration Eliminator is to absorb compressor vibration. By installing a vibration eliminator, the risk of damage to system equipment and pipework is reduced.

### Applications

A vibration eliminator can be installed in both the suction and discharge lines of air-conditioning and refrigeration systems.

Vibration eliminators are suitable for use with HCFC, HFC and CO2 refrigerants along with their associated oils. In addition, models in the Imperial range are suitable for use with A2L gases. Also suitable for use with A2L gases are models listed in the Metric range up to and including the V-7/8 & VS-7/8 sizes.

### Main Features

- Proven design
- Large hose ID
- Stainless steel hose and braid
- Stainless steel ferrules for superior strength
- Helium leak tested
- CE/UKCA Cat marked
- UL listed (V series only)

### Technical Specification

Allowable operating pressure = As per table  
 Allowable operating temperature = -40°C to +120°C (V & VS models)

## VS SERIES

### The V Series

Each unit is constructed of a deep pitch corrugated hose covered with a stainless steel braid. The hose and braid are reinforced by ferrules at each end and connected to copper tube ends by a high temperature braze alloy.

### The VS Series

The VS series is based on the proven design of the V series with a few modifications. The VS series is constructed entirely of stainless steel and all joints are tig welded. Consequently there is no need to wet-rag the product during the installation process. The maximum working pressures are higher, as detailed in the table.

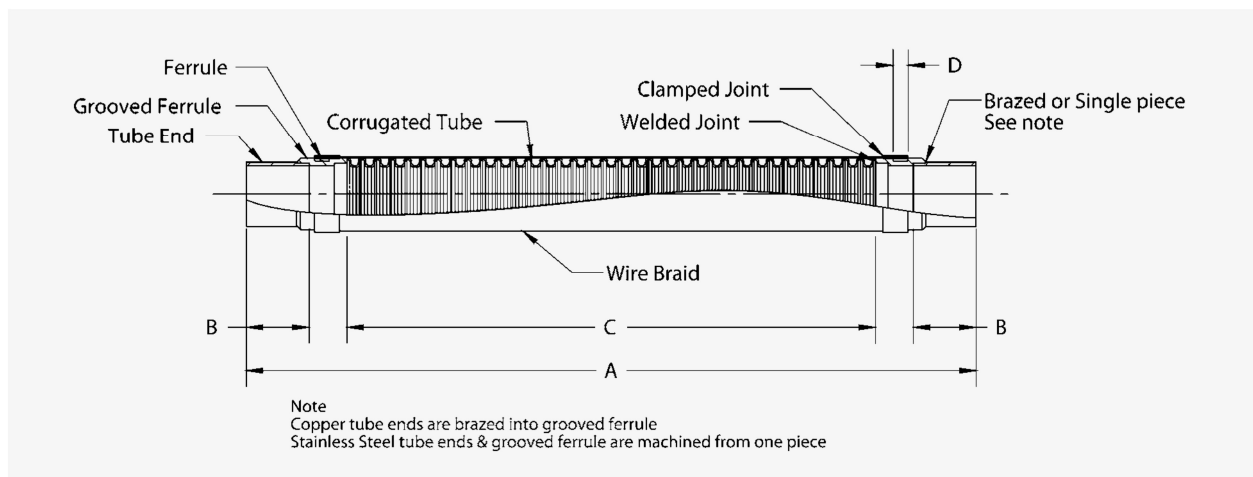

V and VS Series (Imperial range)

Part No		ODS (inch)	Dimensions (mm)				MWP (barg)		Weight (kg)	CE Cat
V Series	VS Series		A	B	C	D	V Series	VS Series		
V-1/4	VS-1/4	1/4	202	17	133	10	44.8	60.0	0.14	SEP
V-3/8	VS-3/8	3/8	215	18	141	10	44.8	60.0	0.14	SEP
V-1/2	VS-1/2	1/2	225	18	151	10	44.8	60.0	0.15	SEP
V-5/8	VS-5/8	5/8	247	20	169	10	44.8	60.0	0.21	SEP
V-3/4	VS-3/4	3/4	266	23	180	11	44.8	60.0	0.32	SEP
V-7/8	VS-7/8	7/8	301	25	211	11	44.8	60.0	0.31	SEP
V-1-1/8	VS-1-1/8	1-1/8	329	32	223	12	41.3	60.0	0.42	Cat II
V-1-3/8	VS-1-3/8	1-3/8	392	35	274	14	37.9	60.0	0.66	Cat II
V-1-5/8	VS-1-5/8	1-5/8	425	40	295	16	35.1	45.0	0.98	Cat II
V-2-1/8	VS-2-1/8	2-1/8	520	50	370	16	27.5	40.0	1.46	Cat II
V-2-5/8	VS-2-5/8	2-5/8	613	60	434	19	24.1	35.0	2.60	Cat II
V-3-1/8	VS-3-1/8	3-1/8	680	70	481	19	22.0	30.0	3.60	Cat II
V-3-5/8	VS-3-5/8	3-5/8	812	85	579	21	13.0	20.0	4.70	Cat II
V-4-1/8	VS-4-1/8	4-1/8	832	90	589	21	13.0	20.0	5.50	Cat II

V and VS Series (Metric range)

Part No		ODS (mm)	Dimensions (mm)				MWP (barg)		Weight (kg)	CE/UKCA Cat
V Series	VS Series		A	B	C	D	V Series	VS Series		
V-6M	VS-6M	6	202	17	133	10	44.8	60.0	0.14	SEP
V-10M	VS-10M	10	215	18	141	10	44.8	60.0	0.14	SEP
V-12M	VS-12M	12	225	18	151	10	44.8	60.0	0.15	SEP
V-5/8	VS-5/8	16	247	20	169	10	44.8	60.0	0.21	SEP
V-7/8	VS-7/8	22	301	25	211	11	44.8	60.0	0.31	SEP
V-28M	VS-28M	28	329	32	223	12	41.3	60.0	0.42	SEP
V-1-3/8	VS-1-3/8	35	392	35	274	14	37.9	60.0	0.66	Cat II
V-42M	VS-42M	42	425	40	295	16	35.1	45.0	0.98	Cat I
V-2-1/8	VS-2-1/8	54	520	50	370	16	27.5	40.0	1.46	Cat II
V-64M	VS-64M	64	613	60	434	19	24.1	35.0	2.60	Cat I
V-67M	-	67	613	60	434	19	24.1	-	2.60	Cat I
V-76M	VS-76M	76	680	70	481	19	22.0	30.0	3.60	Cat I
V-80M	-	80	680	70	481	19	22.0	-	3.60	Cat I
V-89M	VS-89M	89	812	85	579	21	13.0	20.0	4.70	Cat I
V-108M	VS-108M	108	832	90	589	21	13.0	20.0	5.50	Cat I

Note: The V Series is dual CE and UL approved where applicable.

**Installation – main issues**

1. The vibration eliminator should be fitted as close to the compressor as possible and must be installed in a straight line. Vibration eliminators are not designed to compensate for pipework misalignment.
2. Care should be taken to allow sufficient space for the vibration eliminator to avoid static compression or tension, after brazing in place. Vibration eliminators are not designed to absorb axial or torsional stress.
3. Vibration eliminators should be installed perpendicular to the direction of vibration. When vibration exists in two planes, two vibration eliminators should be used. Refer to Figs 1 and 2.
4. For optimum absorption of vibration, the refrigerant line should be anchored at the end of the vibration eliminator furthest from the vibration source.
5. Take special care to install vibration eliminators horizontally when used in suction lines or where operating temperatures are below freezing point. Condensation may form on the outside of the unit and if installed vertically this may accumulate in the lower braid collar. In subsequent freezing this may deform and destroy the unit. If vertical installation is the only option, or indeed if condensation is possible with horizontal mounting, the entire flexible section, ferrules and braided hose, must be covered with a watertight synthetic material e.g. a heat shrinkable PVC sleeve.
6. The ferrule and start of braid must be wet-ragged for brazing when installing the V series to prevent overheating and subsequent damage.

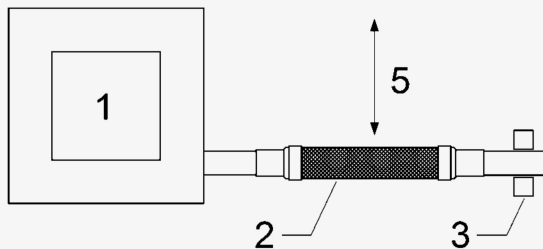

FIG.1 SINGLE SYSTEM

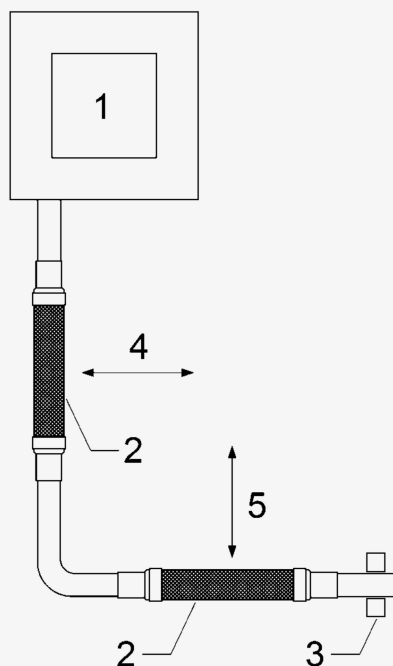

FIG.2 DOUBLE SYSTEM

- ① Compressor
- ② Vibration eliminator
- ③ Secure to solid member
- ④ Horizontal motion
- ⑤ Vertical motion